

KREATYWNY ENERGY POLSKA

Male Energy Storage Supercapacitor



Overview

This review provides an overview of the fundamental principles of electrochemical energy storage in supercapacitors, highlighting various energy-storage materials and strategies for enhancing their performance, with a focus on manganese- and nickel-based materials. Their charge-storage performance is largely influenced by the properties of electrode materials, electrolytes and. Supercapacitors are among the most promising electrochemical energy-storage devices, bridging the gap between traditional capacitors and batteries in terms of power and energy density. In this article, we explore the unique construction.

Male Energy Storage Supercapacitor



Technology Strategy Assessment

Electrochemical capacitors, which are commercially called supercapacitors or ultracapacitors, are a family of energy storage devices with remarkably high specific power compared with other ...

Supercapacitors: A promising solution for sustainable energy storage

Unlike batteries, supercapacitors store energy electrostatically, enabling rapid charge-discharge cycles without significant degradation. However, they typically exhibit lower energy density ...

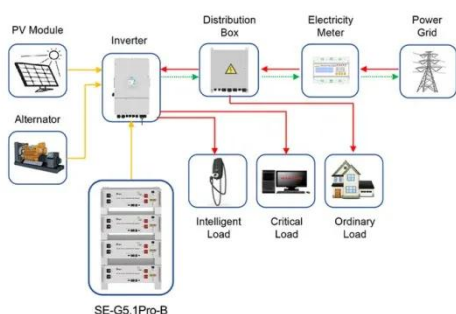

Application scenarios of energy storage battery products

Supercapacitors for energy storage: Fundamentals and materials ...

This review provides an overview of the fundamental principles of electrochemical energy storage in supercapacitors, highlighting various energy-storage materials and strategies for enhancing their ...

Supercapacitors, and the Potential

to Revolutionize Energy ...

Technological research in the domain of energy storage has given birth to a new class of solution that bridges the gap between the properties of both batteries and capacitors: supercapacitors.



A Guide to Types and Applications of Supercapacitors

Supercapacitors can be classified into three main types based on their energy storage mechanisms: To start with EDLC supercapacitors store energy through electrostatic charge ...

Supercapacitors for energy storage applications: Materials, devices ...

Perspectives on optimized design, fabrication, and characterization methodologies that will drive the performance and longevity of supercapacitors to meet diverse energy storage ...

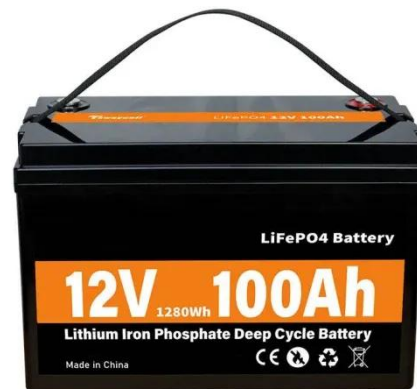

Supercapacitors: An Emerging Energy Storage System

The article also discusses the future perspectives of supercapacitor technology. By examining emerging



trends and recent research, this review provides a comprehensive overview of electrochemical ...

Empowering the Future: Cutting-Edge Developments in ...

These insights aim to guide future research toward realizing high-energy, high-efficiency, and scalable supercapacitor systems suitable for applications in electric vehicles, renewable energy ...



Recent Advanced Supercapacitor: A Review of Storage Mechanisms

Supercapacitors can store large amounts of energy and deliver excellent power, making them ideal for various applications. Supercapacitors are an increasingly attractive option in the race to develop new ...

Contact Us

For catalog requests, pricing, or partnerships, please visit:

<https://kreatywny-dom.pl>

