

KREATYWNY ENERGY POLSKA

Principles of Earth and Solar Power Generation



Overview

This chapter provides a comprehensive overview of the key principles underlying PV technology, exploring the fundamental concepts of solar radiation, semiconductor physics, and the intricate mechanisms that facilitate the transformation of sunlight into a usable electrical. This chapter provides a comprehensive overview of the key principles underlying PV technology, exploring the fundamental concepts of solar radiation, semiconductor physics, and the intricate mechanisms that facilitate the transformation of sunlight into a usable electrical. The amount of sunlight that strikes the earth's surface in an hour and a half is enough to handle the entire world's energy consumption for a full year. Solar technologies convert sunlight into electrical energy either through photovoltaic (PV) panels or through mirrors that concentrate solar. Sun is a gigantic star, with diameter of 1.4 million kilometers releasing electromagnetic energy of about 3.8×10^{26} W. The energy from the sunlight extends from 300 nm to 3000 nm. Majorly, they are classified as Ultraviolet region (less than 350 nm), Visible region (350 nm to 750 nm), and Infrared. Understanding this story is not just an academic journey—it's a look into the very science powering the future of human civilization. However, the majority of. And that is how the flow of electrons is directed toward the external circuit. The Photovoltaic Effect This effect is the fundamental process by which electrons create electric current in solar cells, all thanks to photovoltaic technology. Solar panels, also called PV panels, are combined into. Photovoltaic technology, often abbreviated as PV, represents a revolutionary method of harnessing solar energy and converting it into electricity.

Principles of Earth and Solar Power Generation



How Does Solar Work?

Below, you can find resources and information on the basics of solar radiation, photovoltaic and concentrating solar-thermal power technologies, electrical grid systems integration, and the non ...

Principles of Solar Energy Generation - Energy and environment

The generation of thermal energy from solar can be realized using various solar reflecting collectors. Most of the technology works on the principle of reflection, radiation and convection or based on the ...



ESS

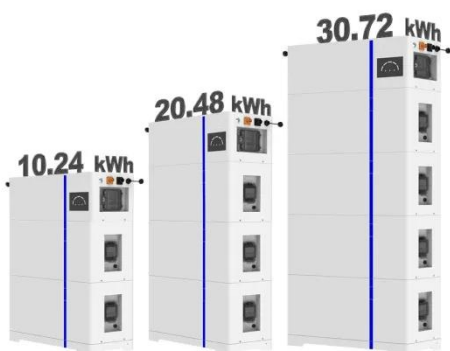

Basic principles of solar energy

This document de-scribes the principle of solar energy to generate electrical energy. Analyze the relationships between voltage, current and power output of photovoltaic cells and how to ...

Chapter 1: Introduction to Solar Photovoltaics

This chapter provides a comprehensive overview of the key principles underlying PV technology, exploring the fundamental concepts of solar radiation, semiconductor physics, and the intricate

...

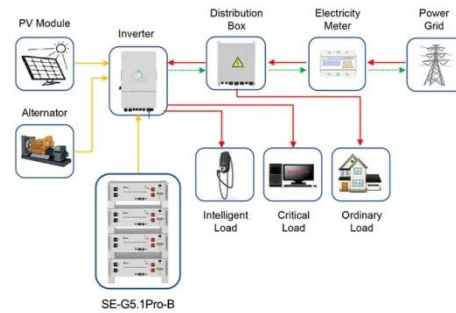

Application scenarios of energy storage battery products



Solar energy

Solar radiation may be converted directly into solar power (electricity) by solar cells, or photovoltaic cells. In such cells, a small electric voltage is generated when light strikes the junction

...

How Is Solar Energy Generated Step-by-Step? A Complete Guide to ...

Solar energy generation follows a structured process to transform sunlight into usable electricity. Each step is essential for efficient energy conversion and distribution. Photovoltaic (PV) cells within solar ...



The Working Mechanism of Solar Power Generation Systems

Learn the detailed working mechanism of solar power generation systems, converting sunlight into clean,



renewable electricity.

How Physics Powers Solar Panels and Renewable Energy

From the atomic dance inside semiconductors in a solar panel to the massive turbines spinning in the wind, physics sits at the heart of renewable energy. Understanding this story is not ...

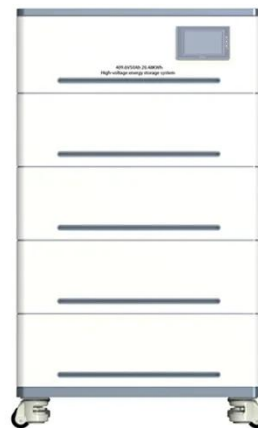

Understanding Solar Photovoltaic (PV) Power Generation

Solar photovoltaic (PV) power generation is the process of converting energy from the sun into electricity using solar panels. Solar panels, also called PV panels, are combined into arrays in a ...

Solar energy

Solar photovoltaic (PV) power generation is the process of converting energy from the sun into electricity using solar panels. Solar panels, also called ...



Principle and materials of solar power generation

This chapter provides a comprehensive overview of the key principles underlying PV technology, exploring the fundamental concepts of solar radiation, semiconductor physics, and the intricate ...

Contact Us

For catalog requests, pricing, or partnerships, please visit:
<https://kreatywny-dom.pl>

